

# KNC-PLC-K533 - Analog I/O Expansion Module



## FEATURES

- **Current and Voltage Inputs**
- **Current and Voltage Outputs**
- **Provides Wide Input/Output Range**
- **Up to 6 Analog Input/Output Modules in One PLC-K5 System**
- **12-bit Conversion for High-Resolution Measurement**
- **Very Reliable +/-0.3% Error**



## DESCRIPTION

The PLC-K533-04IV Analog Input/Output Module was designed to do the job of both the PLC-K531 and PLC-K532 series all on one module. The PLC-K533-04IV is equipped with 2 analog inputs and 2 analog outputs. The PLC-K533-04IV performs a 12-bit conversion on the inputs for high-resolution measurement and can be configured to read voltages or currents of different ranges. The current ranges of the analog inputs are 0-20 mA or 4-20 mA, and the voltage ranges of the analog outputs are 1-5 Vdc or 0-10 Vdc. The analog outputs have a 12-bit output resolution allowing the user to increment in 976uV or 3.9uA steps. The current ranges of the analog outputs are; 0-20 mA or 4-20 mA. The voltage ranges of the analog outputs are 1-5 Vdc or 0-10 Vdc. The K533 series has an accuracy of +/- 0.5% to ensure a precise reading.

## SPECIFICATIONS

Parameter	KNC-PLC-K533-04IV
Analog Inputs	2
Analog Outputs	2
Digital Output Resolution	12-bit
Output Type	4-20 mA, 0-20 mA, 1-5 Vdc, 0-10 Vdc
Input Type	4-20 mA, 0-20 mA, 1-5 Vdc, 0-10 Vdc
Accuracy	±0.5% F.S.
Parameter Configuration	Each Channel Can be Configured Separately via the Kincobuilder Software
Signal Limitation	Cannot Exceed Chosen Range
Error Indication	Red LED for Each Channel
Module Width	50mm

L011164

# KNC-PLC-K533 - Analog Expansion Module



EXPANSION



In each system, the CPU module is arranged in the leftmost end, and expansion modules are connected to the expansion interface on the right.

A cable slot is designed on the left side of each expansion module. The expansion cable can be put in the cable slot to ensure seamless interconnection between modules after installing.

WIRING DIAGRAM

## KNC-PLC-K533-04IV

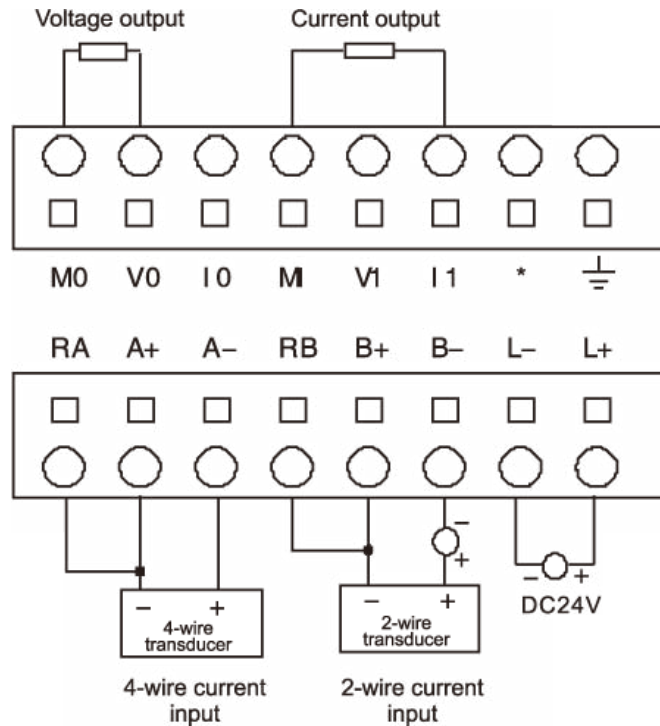

L011164